

DETAIL APPLICABILITY

- A. ALL UTILITIES < 15"
- B. PIPES ≥ 15" AND < 30" DIA. WITH VERTICAL CLEARANCE > 18"

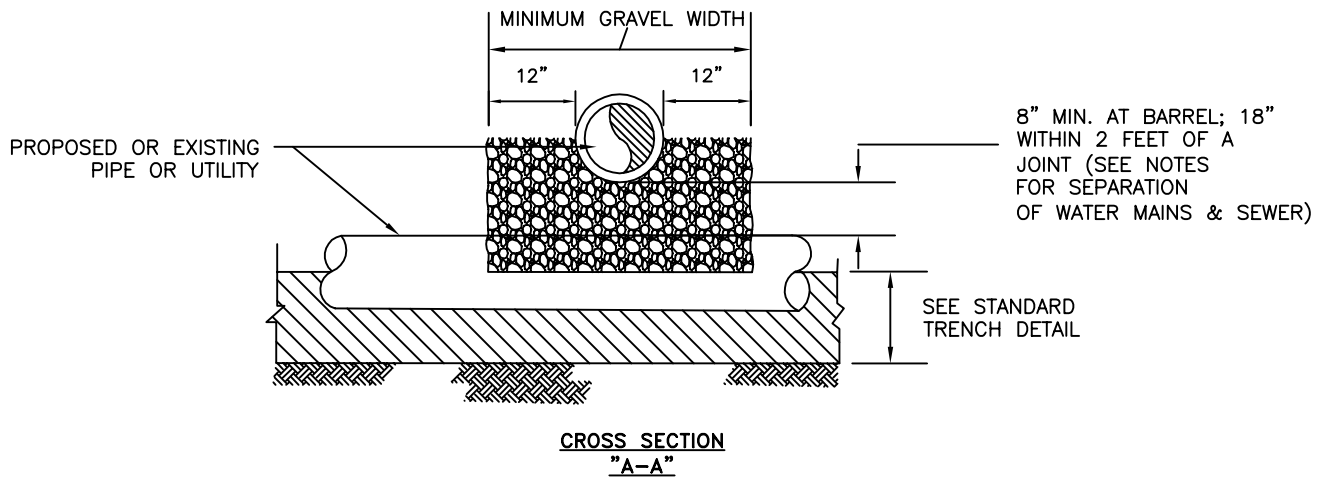
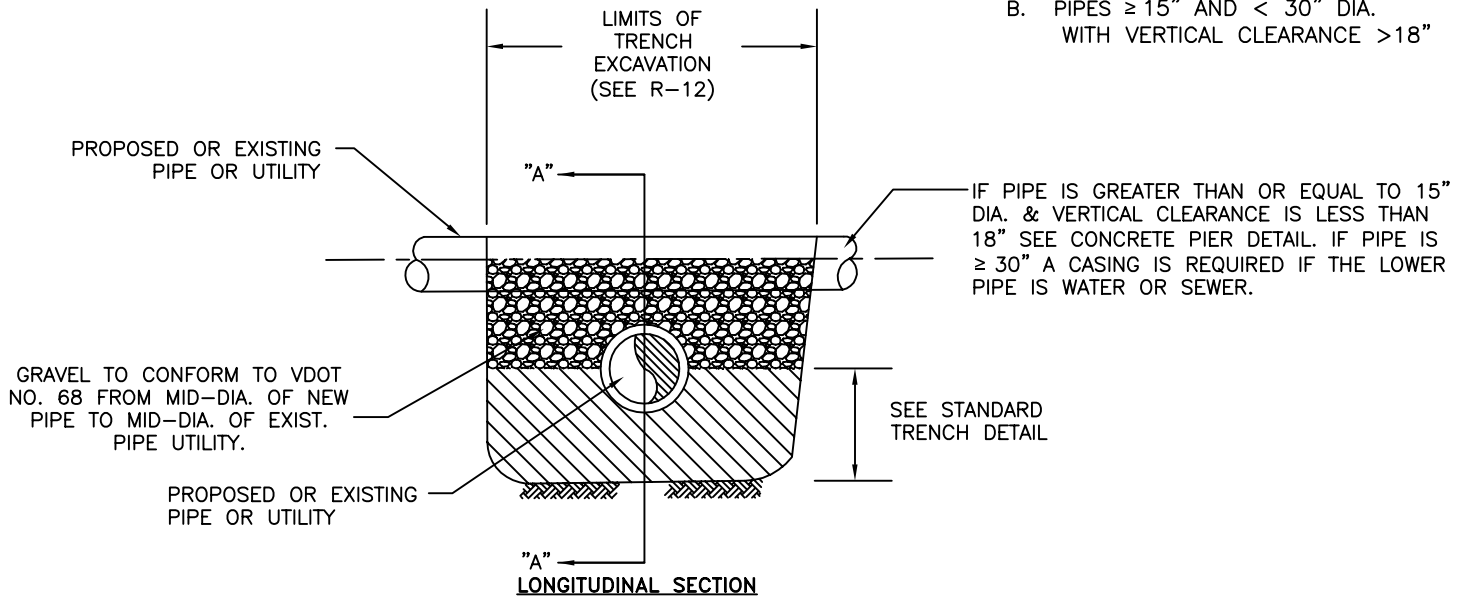

NOTES

1. SEPARATION OF WATER MAINS AND SEWERS AS FOLLOWS:
 - A. UNDER NORMAL CONDITIONS WATER LINES CROSSING SEWERS SHALL BE LAID TO PROVIDE A SEPARATION OF AT LEAST 18 INCHES BETWEEN THE BOTTOM OF THE WATER LINE AND THE TOP OF THE SEWER WHENEVER POSSIBLE.
 - B. UNDER UNUSUAL CONDITIONS WHEN LOCAL CONDITIONS PREVENT A VERTICAL SEPARATION DESCRIBED IN A. (ABOVE)
 - B.1. THE LOWER PIPE SHALL BE ENCASED 10' FROM CROSSING BOTH DIRECTIONS.
 - B.1.a. THAT THE LENGTH OF THE WATER AND SEWER LINE BE CENTERED AT THE POINT OF CROSSING SO THAT THE JOINTS SHALL BE EQUIDISTANT AND SEPARATED AS FAR AS POSSIBLE.

NOT TO SCALE

